

Feb. 16, 1932.

L. M. STADELHOFFER
RADIATOR AND AIR VALVE THEREFOR
Original Filed Dec. 31, 1927

1,845,634

Fig. 1.

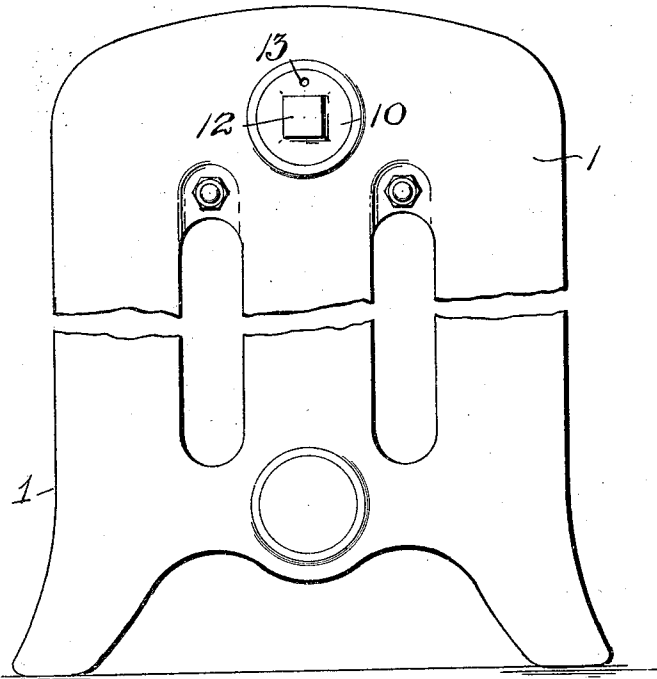

Fig. 2.

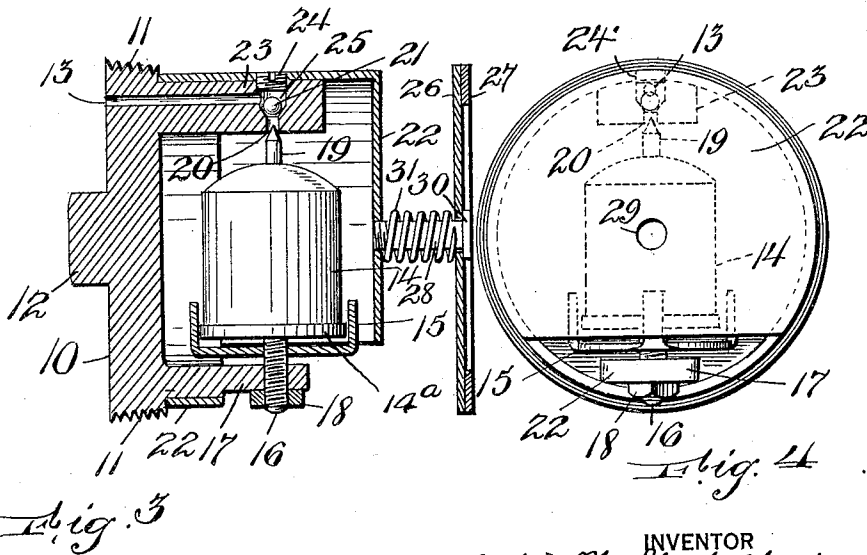
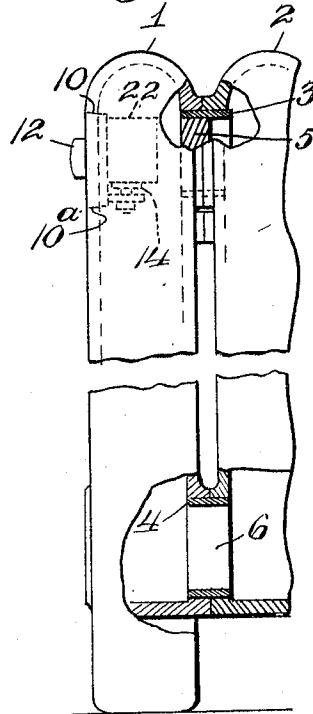

Fig. 3

Fig. 4

INVENTOR
Leslie M. Stadelhofer,
BY
Mrs. H. Campfield,
ATTORNEY.

UNITED STATES PATENT OFFICE

LESLIE M. STADELHOFER, OF NEWARK, NEW JERSEY

RADIATOR AND AIR VALVE THEREFOR

Application filed December 31, 1927, Serial No. 243,803. Renewed July 11, 1931.

My invention relates to new and useful improvements in valves for venting air from heating radiators. While my invention is adapted for use in connection with any of the well known types of radiators, it is particularly adapted for use in connection with radiators employing steam as a heating medium, and usually consisting of a plurality of chambered or hollow elements connected communicatively for circulation of the heating medium—for example, radiators built up of a plurality of chambered sections connected communicatively to each other at their upper and lower portions by flow passages, usually through nipples either of the so-called push or screw type which serve to couple the sections.

In radiators of the character just mentioned, the end and intermediate sections are usually similar and are provided at their upper and lower end portions with oppositely disposed, and axially aligned flow passages which receive the said nipples connecting the sections, so that when the sections are assembled to form the radiator, an end section has an outer nipple opening which does not constitute a flow passage, but is sealed by a plug threaded into said opening.

When radiators of the character above described are employed in what is known as a one pipe steam system, the steam entering one of the end sections flows partly upward through the end section and across the top of the radiator through the passages connecting the radiator sections and thence downward through the sections, displacing the air, and part of the steam flows through the connecting flow passages at the bottom of the radiator and upward in the sections, thus pocketing the air and retarding displacement thereof. Also steam which passes through the upper flow passages flows into the end section to which some form of thermostatic air valve is usually applied, and heats the thermoresponsive part of the valve so as to close the same before all of the air is vented, with the result that the pocketed air remains in the radiator and prevents steam from flowing in heat transfer contact with the entire surface of the radiator, thus preventing heating of the radiator to its intended capacity.

A valve constructed according to my invention preferably embodies as one of its features the prevention of air being pocketed or trapped, and for this purpose includes provision for closing the upper flow passage between the section to which the valve is applied and the remaining sections of the radiator and to cause the steam to enter said section only at the base thereof, so that the steam displaces substantially all of the air through said section before the steam can heat the vent valve sufficiently to close it, with the result that radiators of the type mentioned can be employed at their rated heating capacity, because there will no trapped air to prevent the steam from flowing in contact with substantially the entire heat transfer surface of the radiator.

One of the objects of my invention is to provide an improved venting valve which will effectually vent radiators of the type mentioned when employing steam as the heating medium.

A further object is to provide a venting valve having means for preventing the steam from prematurely closing the venting valve before the air is effectually vented from the radiator, and thereby prevent pocketing or trapping of air in the radiator to such extent as to materially lower the intended heating efficiency of the radiator.

A further object is to provide a venting valve which can be mounted in a usual nipple opening in the end section or loop of a radiator, in such manner that the valve-actuating device will be effectively responsive to a controlling condition in the radiator, and such valve and device will be concealed from external view.

A further object is to provide a thermostatically actuated valve which can be supported in the outer nipple opening of an end section or loop of a radiator and which will carry means for closing the nipple opening between the outer section or loop and the next adjacent section, whereby the end loop or section carrying said valve will communicate with the other section or sections only at the bottom thereof, so that the steam and displaced air will be compelled to enter the end section only at the bottom thereof, and be prevented from flowing or short-circuiting through the upper nipple opening into the end section and by prematurely heating the valve cause the same to close before all of the air is vented from the radiator.

A further object is to provide an improved and efficient thermostatically controlled air valve, the thermo-sensitive mechanism of which when the valve is applied in operative position to a radiator, will be concealed in the interior of the radiator, and which will have no part or parts protruding from or exposed outside the radiator except such provision as may be necessary for venting, and for engagement by a tool in order to apply or remove the valve.

The invention consists in the novel construction and combination of parts in operative arrangement, to be more fully described hereinafter, and the novelty of which will be particularly pointed out and distinctly claimed.

The drawings attached hereto which form part of this specification illustrate one form of my improved radiator and air valve and Figure 1 is an end view of the radiator with an embodiment of my improved air valve in position and Figure 2 is a side view of the same partly broken away and partly in section. Figure 3 is a central vertical section of an embodiment of my improved air valve and Figure 4 is a back view thereof.

The radiator shown in the drawings consists of the required number of communicatively connected hollow sections and I show only the last two as the others are similar and are supplied by a steam pipe connected to the bottom opening of the first section which pipe is also used to convey water of condensation back to the heater. This is the usual single pipe steam system.

In the drawings the last section of the radiator is shown at 1 and the next to the last section is shown at 2. The top openings of the sections are connected communicatively by a nipple 3 and the bottom openings by a nipple 4. The top nipple 3 can be stopped by a plug 5 or it can be a solid pipe thus forming a plug in itself, or it may be closed by the improved closure forming part of my improved valve. It will be evident that by closing the flow passage through the nipple 3 steam entering the radiator can

not pass directly through the nipple 3 and across the top of the radiator to the air valve 10 but is deflected by the plug 5 and is forced to flow down through the intermediate sections so that all the steam from the radiator must pass through the opening or channel 6 in the bottom connection, and be forced to heat the sections successively and completely and the last section be heated last. This is due to the tendency of the steam to rise which it does in the first section that it enters and it passes along through the intermediate top nipples 3 until it hits the plug 5 or its equivalent. The steam in the meantime has been passing through the lower nipples 4 but more slowly due to its tendency to rise and both of these flows of steam are directed toward the passage 6 between the last two sections and at the bottom. This construction allows no cold air pockets to be formed in the sections and the heating of the radiator is prompt.

The valve comprises a suitable casing or support which is secured in the wall of a radiator with the valve proper on the inside face or side of the device so as to be responsive to a controlling condition in the radiator. This support is preferably in the form of a plug 10 which has a screw-threaded rim 11 or an equivalent means for securing it into the opening 10^a whereby the latter is sealed.

In the modern radiator the hole 10^a in which the plug 10 is screwed is already provided as it is utilized in connecting adjoining sections and closed by a plug when it happens to be the last section. This opening is near the top of the radiator and is at the end farthest from the steam inlet so that all the cold air can pass from the radiator as the place where the air valve is placed is the farthest removed from the steam inlet.

The form of valve shown has a lug or wrench head 12 which receives a wrench and by which the plug 10 is screwed and unscrewed. The plug has an air vent passage 13 through it and this is provided with an outlet located preferably at the top of the thermostatic valve so that the steam fitter knows that when the opening 13 is uppermost as shown in Figure 1 that the valve is in proper upright position for successful operation, thus acting as a guide for the proper installation of the air valve.

A suitable thermostatic valve is supported on the inner side of the plug 10 and I show the same as consisting of a thermostatic chamber and float 14 which is supported by the guide-holder 15, and the float rests on a screw 16 which is in screw-threaded engagement with the arm 17 of the plug, said screw being held in position by a lock nut 18. The float 14 is provided with a flexible diaphragm bottom wall 14^a, and is supplied with a volatile liquid which when heated expands the float at the bottom which is made of thinner material than the rest of the float and

therefore raises it. This expansion raises the float and causes the valve stem 19 fixed to the upper end of the float to close the inlet 20 of the passage 13 which forms a valve seat for the stem. When the radiator cools the reverse takes place and the passage 13 is open. To prevent cold air returning to the radiator and especially in vacuum systems the ball 21 is located on the valve seat 20 and acts as a check valve. Should for any reason water of condensation collect in the radiator in sufficient quantity to reach the level of the thermostatic float 14, the latter will rise by its buoyancy and seat the valve 19 to close the inlet 20 and thereby prevent water being emitted through the vent passage 13. When the water level recedes, the float valve drips back to its normal position on the screw 16 and opens the vent passage 13 to permit escape of air, provided the temperature in the radiator is not high enough to expand the float to close the valve.

The cap or cover 22 is open at the bottom but covers the major and upper portion of the thermostatic valve whereby the chance of damage to the thermostatic valve is reduced but the steam is allowed to have quick and ready access to the valve. The open bottom of the cover 22 also permits access of the water to the float should the water level rise in the manner above described. The shell 22 is secured to the upper arm 23 of the plug 10 by the screw 24 which not only secures the shell but acts as a plug for the opening 25 which holds the ball 21.

The parts of the thermostatic valve are of such size and so disposed as to bring them within the circumference of the rim 11 of the plug 10 so that they can pass in and out of the opening 10^a in which the plug 10 fits.

The old forms of valves form their own levers for turning them into and out of position and are thus easily stolen. This amounts to a great loss in many institutions and other buildings whereas with this valve, with its flat face except for the wrench receiving projection, can not be taken out without the use of a wrench.

As a closure for the opening or nipple 3 at the top of the last two sections I may place a stopper or lid on the air valve and thus close this opening when the air valve is installed. I show such closure at 26 in Figure 3. This is shown as a disc of metal with a felt or similar washer 27 to fit against or within the nipple 3. The disc 26 is slidably supported on the post 28 which can be screwed into the hole 29 in the end of the casing 22. The head 30 prevents the disc from coming off and the spring 31 provides a resilient means for holding the closure shut against ordinary steam pressure as used in house heating systems and this without regard to the exact distance the plug 10 is screwed into the opening in the radiator. Upon reference to Fig. 3 of the

drawings, it will be seen that the aperture in the center of the disk 27 is of slightly larger diameter than the diameter of the post 28, so as to provide a slight clearance between the plate and the post, whereby the disk may to a certain extent rock on the post, and thus automatically adjust its outer face to the edge of the nipple 3 when the valve is applied to a radiator. By providing for the yielding and rocking movement of the disk, the latter seats throughout its periphery on the edge of the nipple 3 and thus effectively closes the opening through the nipple. The disk 27 performs an important function in assuring proper venting of the radiator, in that it prevents the steam from short-circuiting through the upper nipples, and by coming in contact with the thermostatic float causing the valve to close before the air is effectively vented from the radiator. By my provision the steam and air pass through each section of the radiator in turn, and all the air is forced into the bottom nipples and thence forced up the last section through the bottom opening therein, by this arrangement substantially all of the air is driven out of the radiator before the valve closes, and pocketing or trapping of the air is prevented which is of obvious importance and advantage, because it is well known that air trapped in a radiator reduces its heating value because the air prevents the steam coming in direct contact with the heat transfer surface of the radiator.

I claim:—

1. An air valve for radiators comprising a plug with a screw-threaded rim, and having arms extending from its inner face, a thermostatic valve supported on one arm, and operating on a valve seat in the other arm, the valve seat being at the inner end of an air passage which extends to the outside face of the plug.

2. An air valve for radiators comprising a plug with a screw-threaded rim, and having upper and lower arms extending from its inner face, a thermostatic valve supported by the lower arm and operating on a valve seat at the upper arm, the valve seat being in the inner end of an air passage which extends to the outside face of the plug and a casing covering the valve and having an open bottom to allow the steam in the radiator to act directly on the thermostatic valve.

3. The combination of a radiator section having openings in its opposite walls, with an air valve comprising a thermostatic valve having an air outlet for venting a radiator, the valve having means for securing it in an opening in one wall of the radiator section and having a closure in extension thereof to close the opening in the opposite wall of the section.

4. An air valve for radiators comprising a casing, a thermostatic valve in the casing,

a closure in extension of the casing and adapted to close an internal flow passage in a radiator to which the valve may be applied and a support for the closure.

5 5. An air valve comprising a casing to fit into an opening in a radiator, a thermostatically operated valve mechanism in the casing, and a yieldingly supported closure supported by the casing and extending from the back thereof and adapted to close an internal flow passage in a radiator when said valve is applied thereto.

10 6. A device of the character described, comprising an element adapted to close an opening in a wall of a radiator, said element having a vent passage therethrough, a valve carried by said element and controlling said passage, and a closure member carried by the inner portion of said element and adapted to close a flow passage in a radiator.

15 7. A device of the character described, comprising a screw plug adapted to be threaded into an opening in a wall of a radiator, said plug having a vent passage, a thermostatically actuated valve to control said vent passage and supported at the inner portion of said plug and adapted to be exposed to a temperature condition in a radiator, and a closure member carried by the inner portion of said plug beyond said valve and adapted to close a flow passage in the radiator opposite to the opening in which said screw plug is threaded.

20 8. A device of the character described, comprising an element adapted to close an opening in a wall of a radiator and having a rearwardly extending member adapted to project into a radiator, said element and member having a vent, said vent having a downwardly directed valve seat, a vertically movable valve beneath said member and cooperating with said seat, and means supported by said element below said member and responsive to a condition in a radiator to actuate said valve.

25 9. A device of the character described, comprising an element adapted to close an opening in a wall of a radiator and having a rearwardly extending member adapted to project into a radiator, said element and member having a vent, said vent having a downwardly directed valve seat, a valve cooperating with said seat, and a thermostatic float supported on said element below said member and operable to actuate said valve.

30 10. A device of the character described, comprising an element adapted to close an opening in a wall of a radiator, said element having a vent, valve means carried by said element and responsive to a condition in a radiator to control said vent, and a closure member carried by said element and adapted to close an internal flow passage in a radiator.

35 11. A device of the character described,

comprising a plug having a screw thread whereby the same may be screwed into an opening in a radiator, said plug having a vent, said vent having a valve seat at the inner portion of said plug, a valve responsive to a condition in a radiator and co-operable with said seat to open and close said vent, and means carried by said plug at the inner portion thereof to close a flow passage in a radiator.

40 12. A device of the character described, comprising a plug having a screw thread whereby the same may be screwed into an opening in a radiator, said plug having a vent, said vent having a valve seat on the inner portion of said plug, a valve responsive to a condition in a radiator to open and close said vent, means carried by said plug at the inner portion thereof to close a flow passage in the radiator, and means whereby said last-named means cooperates with said flow passage to close the same by screwing the said plug into operative position in a radiator.

45 13. A device of the character described for use in connection with a radiator comprising sections connected by a flow passage, and one of which sections has an external opening in line with said flow passage, said device comprising a plug adapted to close said opening and having a vent therethrough, a valve carried by the inner portion of said plug and having means responsive to a condition in a radiator to cause said valve to open and close said vent and a closure member mounted on said plug and adapted to close the radiator flow passage in line with said opening.

50 14. A device of the character described comprising an element adapted to close an opening in a radiator wall, said element having a vent, a valve carried by the inner end of said element and adapted to open and close said vent, said valve having operating means responsive to a condition in a radiator, and a closure member yieldingly mounted on said element and adapted to close an internal flow passage in a radiator when said device is applied thereto.

55 15. A device of the character described comprising an element adapted to close an opening in a radiator wall, said element having a vent, a valve carried by the inner end portion of said element and adapted to open and close said vent, said valve having operating means responsive to a condition in a radiator, a guide member mounted on said element, a closure member movable on said guide member, and resilient means urging said closure member in one direction, said closure member being adapted to yieldingly close an internal flow passage in a radiator.

60 16. A device of the character described, comprising an element adapted to close an

opening in a wall of a radiator, said element having a vent for escape of air in one direction from a radiator, valve means carried by said element and responsive to a condition in a radiator to control outward flow from the radiator through said vent, a check valve cooperating with said vent to prevent inward flow of air through said vent, and a closure member carried by said element and adapted to close an internal flow passage in a radiator.

17. A device of the character described comprising a threaded plug adapted to be screwed into a nipple opening of a radiator, said plug having at its rear portion a member to project into a radiator, said member having a vent passage therein and extending through said plug, said vent passage having an inlet port surrounded by a valve seat, a thermostatic float supported by said plug and carrying a vertically movable valve cooperable with said valve seat to open and close said inlet port.

18. A device of the character described comprising a threaded plug adapted to be screwed into a nipple opening of a radiator, said plug having at its rear portion a member to project into a radiator, said member having a vent passage therein and extending through said plug, said vent passage having an inlet port surrounded by a valve seat, a thermostatic float supported by said plug and carrying a vertically movable valve cooperable with said valve seat to open and close said inlet port and a closure device for an internal flow opening in a radiator, said closure device being supported on said plug by means permitting said closure device to be automatically adjusted to said flow opening by screwing said plug into the radiator nipple opening.

19. A device of the character described comprising a plug adapted to be inserted, an opening in a wall of a radiator, and having a vent passage, a thermostatic float valve supported on the inner end of said plug so as to be located inside the radiator when said plug is mounted in said opening, and a closure carried by the inner portion of said plug and beyond said valve relative to said plug, and operable to close an internal flow passage in a radiator when said plug is inserted in operative position in said radiator opening.

20. A device of the character described, comprising an element adapted to close an opening in a wall of a radiator, said element having a vent for escape of air in one direction from a radiator, valve means carried by said element and responsive to a condition in a radiator to control outward flow from the radiator through the vent, and a check valve cooperating with said vent to prevent inward flow of air through said vent.

21. A device of the character described,

comprising an element adapted to close an opening in a wall of a radiator, said element having an air vent therethrough, valve means carried by the inner portion of said element for location within a radiator and responsive to a condition in a radiator to control automatically said vent, and a casing enclosing said valve means and the inlet to said vent and having an opening through its wall through which opening the interior of the casing communicates with the interior of a radiator.

22. A device of the character described, comprising an element adapted to close an opening in a wall of a radiator, said element having an air vent therethrough, valve means carried by the inner portion of said element for location within a radiator and responsive to a condition in a radiator to control automatically said vent, and a casing enclosing said valve means and the inlet to said vent and having an opening through its wall through which opening the interior of the casing communicates with the interior of a radiator and means carried by said casing to close an internal flow passage within a radiator when said device is applied thereto.

23. A device of the character described, comprising an element adapted to close an opening in a wall of a radiator, said element having an air vent therethrough, valve means carried by the inner portion of said element for location within a radiator and responsive to a condition in a radiator to control automatically said vent, and a casing enclosing said valve means and the inlet to said vent and having an opening through its wall through which opening the interior of the casing communicates with the interior of a radiator, a guide member mounted on said casing, a movable closure member guided by said guide member, and resilient means urging said closure member in one direction to close an internal flow passage in a radiator.

24. An air valve for radiators comprising a casing having a vent passage, a valve in the casing and cooperating with the vent passage, a closure in extension of the casing, a support for said closure, and a spring acting on said closure to close an internal flow passage in a radiator to which the air valve is applied.

25. An air valve for radiators comprising a plug with a screw-threaded rim, and having arms extending from its inner face, a thermostatic valve supported on one arm, and operating on a valve seat in the other arm, the valve seat being at the inner end of an air passage which extends to the outside face of the plug, and a check valve to prevent the inward flow of air through said air passage.

26. An air valve for radiators comprising a plug with a screw-threaded rim and having

arms extending from its inner face, a ther-
mostatic valve supported on one arm, and op-
erating on a valve seat in the other arm, the
valve seat being at the inner end of an air
5 passage which extends to the outside face of
the plug and a guide on said one arm for
guiding said thermostatic valve relative to
its seat.

10 In testimony whereof I affix my signature.
LESLIE M. STADELHOFER.

15

20

25

30

35

40

45

50

55

60

65